

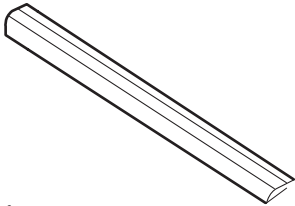

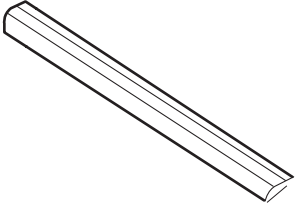



# INSTALLATION INSTRUCTIONS

Accessory	Application	Publications No.
<b>ROOF RACK</b> P/N 08L02-SCV-100	<b>2003 ELEMENT</b>	<b>All 24304</b>
		Issue Date
		<b>DEC 2002</b>

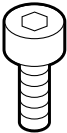
## PARTS LIST

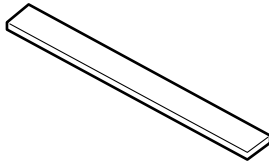
- Front roof rack 
- Rear roof rack 
- 4 End covers 
- 12 Socket bolts 
- 12 Plain washers 
- 4 Rubber seals 

## TOOLS REQUIRED

- Flat-tip screwdriver
- 5 mm Hex wrench
- Isopropyl alcohol
- Shop towel
- T-25 Torx wrench

## INSTALLATION

**NOTE:** Be careful not to damage the roof and other finished surfaces of the body when installing the roof rack.

1. Using a flat-tip screwdriver wrapped with a shop towel, remove the two front covers and two rear covers from the roof trim.

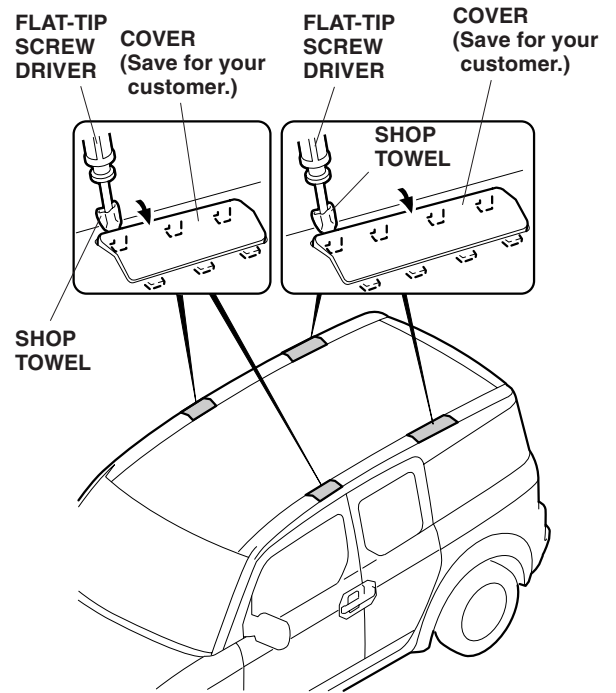

2. Clean the rubber seal attachment position with a shop towel moistened with isopropyl alcohol.
3. Remove the adhesive backing from the back of the rubber seal and attach the rubber seal on the inside of the roof trim as shown.
  - When attaching the rubber seal, align the center of the rubber seal with the hole at the center of the roof rack installation base as shown.
  - Attach the rubber seal with the ends aligned at the beginning of the curvature as shown.

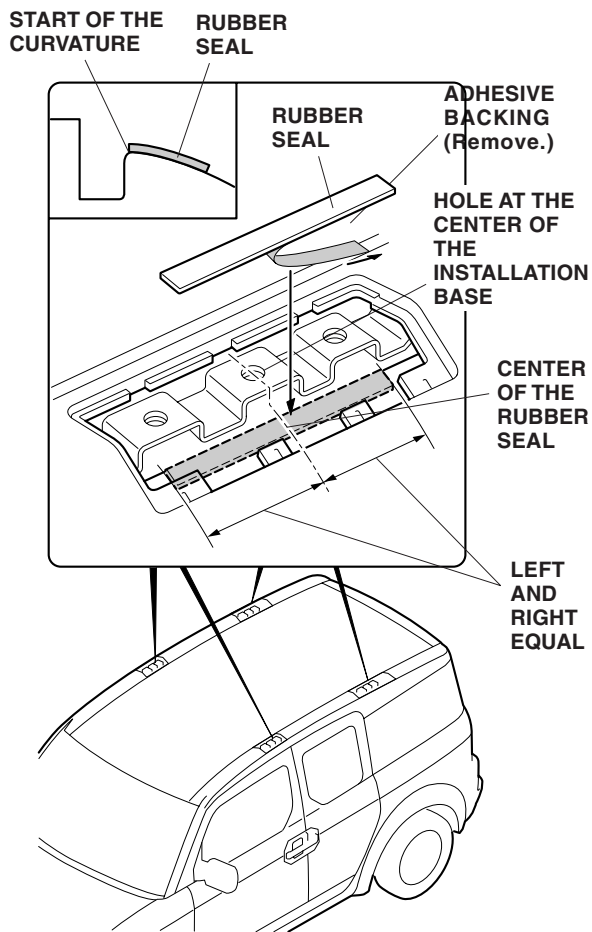

4. Attach the rubber seals to the remaining three locations in the same manner.

5. Position the front and rear roof racks on the roof in the proper locations as shown.

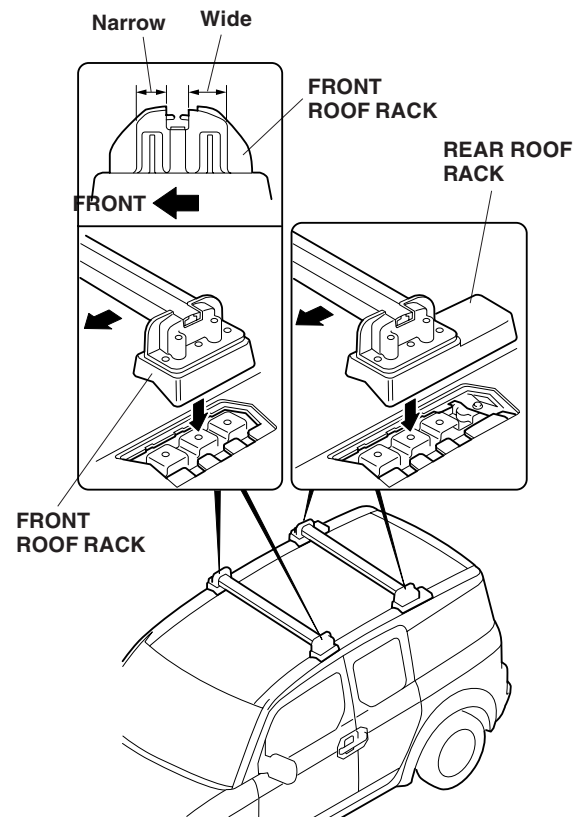

6. If the ends of the right and left roof racks are not aligned, adjust them by loosening the crossbar socket bolts and moving the stays in or out as necessary.

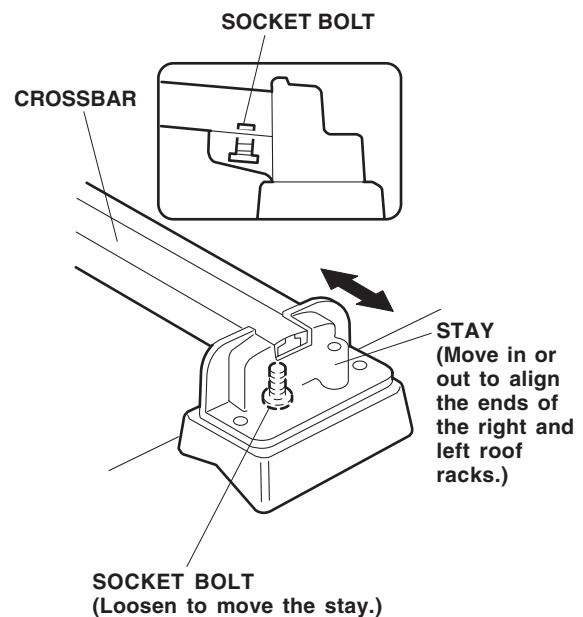

7. Temporarily tighten the 12 socket bolts and 12 washers.

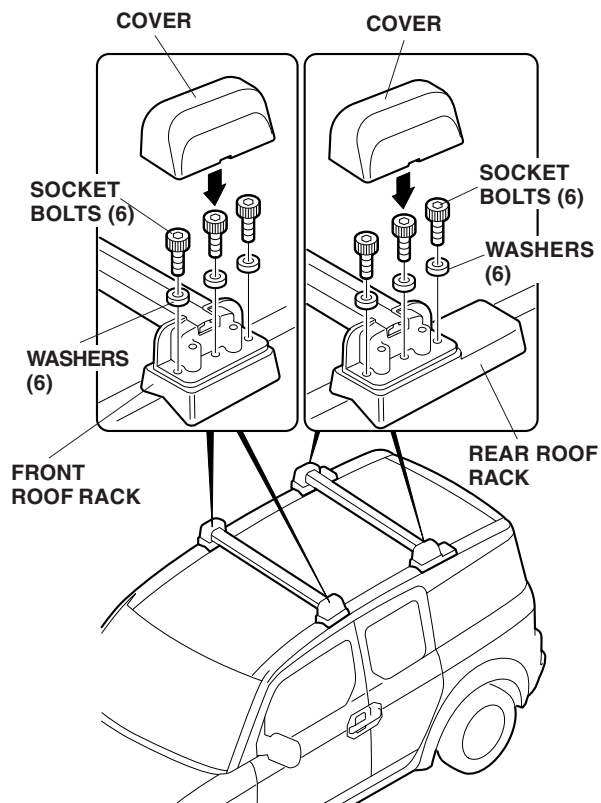

8. Tighten the socket bolts (if loosened in step 6). Torque the socket bolt to 9-10 N·m (6-7 lb-ft)
9. Install the four end covers.
10. Place the covers (removed in step 1) in the glove box for your customer in the event that the roof rack is removed.